



Dual Reference Adaptor 167 (Model EA167)



- Transparent operation — no software required!
- Converts 3–electrode potentiostat to 4–electrode operation
- Electrometer grade amplifier
- Ideal for membrane or ITES samples
- Works with most types of 3–electrode potentiostat

Description

The eDAQ Dual Reference Adaptor 167 is a high impedance differential electrometer.

The Dual Reference Adaptor connects to the reference electrode lead of a 3–electrode potentiostat (for example any of the eDAQ EA161, EA163, EA162, or EA164, modular potentiostats, or the ER466 integrated potentiostat) and enables its use with two reference electrodes. The potentiostat thus becomes a 4–electrode system with one working, one counter, and two reference electrodes.

Applications

Applications include measurements of potential across:

- membranes (4–electrode voltage clamp), or
- the interface between two immiscible electrolyte solutions (ITES), or other liquid junction.

When used with a potentiostat, the potentiostat monitors the current between the working and auxiliary electrodes, while the potential difference between the two reference electrodes (RE 1 and RE 2), is measured by connecting RE Out to the potentiostat reference electrode input.

Most brands/models of 3–electrode potentiostat are compatible.

The EA167 can also be connected to a voltmeter to provide a high impedance differential input reading device.

Ordering

The unit can be ordered as model EA167 Dual Reference Adaptor. This includes hardware unit and cables. The optional EC500 12 V DC mains adaptor can provide power if non-eDAQ potentiostat is being used. No software is required.

Specifications

Input signal:	Ref 2 – Ref 1 $\leq \pm 10$ V
Maximum input:	30 V (10 kohm input protection)
Output signal:	± 10 V maximum (= Ref 2 – Ref 1)
Output accuracy:	± 1 mV + 0.02% of full scale
Input impedance:	10 ¹³ ohm (differential) 10 ¹⁴ ohm (single ended)
Bandwidth:	30 kHz @ full power 500 kHz maximum, for small signals
Common mode rejection:	> 80 dB (DC to 1 kHz with 1 kohm imbalance)
Input bias current:	< ± 100 fA typical, ± 250 fA maximum
RMS noise:	< 5 μ V @ 0 – 1 kHz < 2 μ V @ 0 – 100 Hz < 1 μ V @ 0 – 10 Hz
Input offset:	< ± 0.5 mV typical, 5 mV maximum
Slew rate:	2 V/ μ s
Shields:	Provided on RE 1 and RE 2 Driven (1 kohm source resistance)
Input connectors:	RE 1 and RE 2, both BNC with driven shield.
Output connectors:	RE Out, 2 mm socket COM, 2 mm socket
Physical Configuration	
Dimensions (w x h x d):	130 x 35 x 170 mm (5.1 x 1.4 x 6.7 in)
Weight:	0.73 kg (1 lb 8 oz)
Power Requirements:	12 V DC, 100 mA
Operating conditions:	0 to 35 °C 0 to 90% humidity (non-condensing)

eDAQ Pty Ltd reserves the right to alter these specifications at any time.

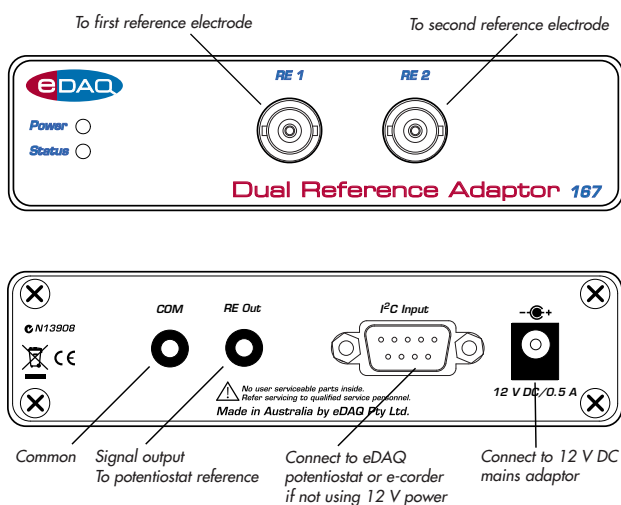

Figure 1. Front and back panels of the Dual Reference Adaptor.

Dual Reference Adaptor Instructions

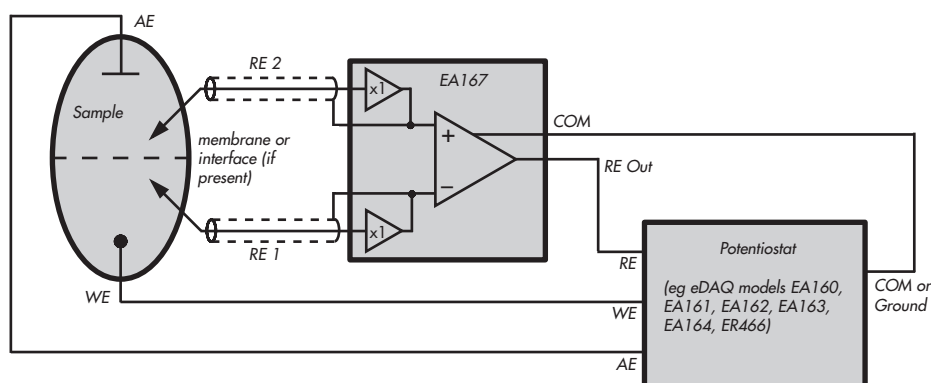

Figure 2. Connection of the EA167 Dual Reference Adaptor to a 3-electrode potentiostat for 4-electrode voltammetric or electrochemical impedance experiments or 4-electrode conductivity measurements. Note that electrodes at AE and RE 2 should be on the same side of the membrane, or interface, in the sample, while the electrodes at WE and RE 1 should be on the other side.

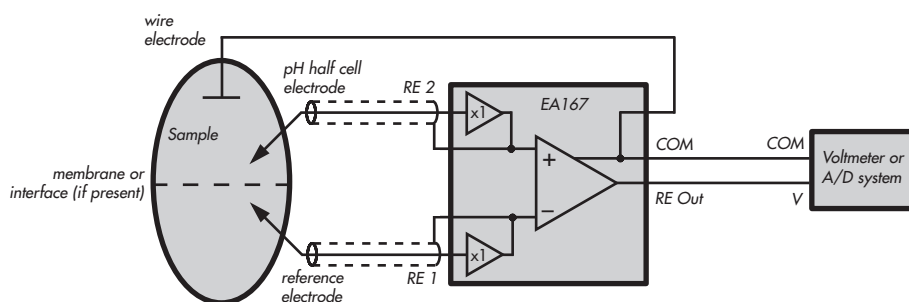

Figure 3. Connection of the EA167 Dual Reference Adaptor for high impedance potential measurements with a voltmeter, or data acquisition system. The example of a pH half cell electrode with a reference electrode is shown, however these could be any pair of electrodes (of high or low impedance). The low impedance 'wire electrode' is usually made of platinum or other inert metal, it can be placed on either side of a membrane, but if there is an interface between two immiscible solutions then position the wire electrode in the more conductive solution. Use this arrangement if you want to compare the potentials of two reference electrodes in the same electrolyte solutions, or two reference electrodes in two electrolyte solutions joined by a salt bridge (for example for the determination of liquid junction potentials as in Barry et al, at <http://aups.org.au/Proceedings/41/74P/74P.pdf>)

Front and Back Panels

The front and back panels of the unit are shown in Figure 1. If using the EA167 with an eDAQ potentiostat then connect the I²C Input on the back panel to the I²C Output on the eDAQ potentiostat to provide power.

The EA167 can also be used with other brands of potentiostat, or with voltmeters, or many types of data acquisition systems. (optional EC500 12 V DC mains adaptor required).

Membrane or Interface Experiments

Consult Figure 2 for instructions on how to connect the EA167 to a 3-electrode potentiostat. In particular, note that electrodes at AE (auxiliary electrode) and RE 2 should be on the same side of the membrane, or interface, in the sample, while the electrodes at WE (working electrode) and RE 1 should be on the other side.

If you are performing EIS (electrochemical impedance spectroscopy experiments) with small amplitude perturbations, eg 100 mV or less, then you can expect the EA167 to perform at its full bandwidth specification (500 kHz) although your total experimental bandwidth may be limited by other system components (eg the potentiostat, or frequency response analyzer).

Potentiostat Polarity

The EA167 produces a voltage signal at RE Out that is the difference between the potential measured at RE 2 relative to RE 1, which can be expressed:

$$RE\ Out = RE\ 2 - RE\ 1$$

As shown in Figure 2, the working electrode is usually held at electrical ground (or virtual ground), which is equivalent to COM (common) at RE Out relative to the COM of the Potentiostat. Thus the EA167 produces a polarity inversion so that if you are using the connections in Figure 2, and set the potentiostat to +0.5 V then the WE will be about -0.5 V (close to the value of RE 1) relative to RE 2. However, a value of +0.5 V will be seen at RE Out.

Thus when using the EA167 with a potentiostat remember that you may have to use the opposite sign of the potential you require at RE 1! For example use a setting of -0.7 V to make RE 1 +0.7 V relative to RE 2.

Use as an Electrometer

See Figure 3 for how to use the EA167 as a high impedance differential input with a voltmeter, or A/D system. Note especially the use of an 'indifferent' wire electrode which provides a low impedance pathway to the sample.